

NOTE

1. EXTEND MAILBOX BEYOND EDGE OF SUPPORT TO ALLOW FOR HINGE ON DOOR. ATTACH BOARD HOLDING BOX TO POST WITH SCREWS OR DOUBLE HEADED NAILS, PERMITTING EASY REMOVAL IF NECESSARY.
2. MAILBOX NUMBER SHALL BE PERMANENTLY MARKED (PAINTED) ON THE BOX IN NUMERALS NOT LESS THAN ONE INCH HIGH.
3. PRIOR TO EXCAVATING SUPPORT POST FOUNDATION HOLE, THE HOMEOWNER SHALL CONTACT THE VILLAGE OF WHEELING AT 847-459-2620 AND J.U.L.I.E. AT 1-800-892-0123 48 HRS. PRIOR TO DIGGING IN ORDER TO AVOID DAMAGE TO UNDERGROUND UTILITIES OR INJURY(IES) TO PERSON(S).
4. ALL MAILBOX SUPPORTS AND ANY VARIATION TO THIS STANDARD MUST BE APPROVED BY THE VILLAGE OF WHEELING PRIOR TO INSTALLATION.
5. MAILBOX FACE SHALL NOT BE CLOSER THAN 6" FROM BACK OF CURB OR EDGE OF PAVEMENT IF THERE IS NO CURB.
6. IT IS UNLAWFUL TO ERECT, BUILD, CONSTRUCT, PLACE OR MAINTAIN ANY TYPE OF PERMANENT NON-BREAKAWAY SUPPORT STRUCTURE AS PART OF OR TO HOUSE A ROADSIDE TYPE MAILBOX WITHIN A SINGLE-FAMILY RESIDENTIAL DISTRICT.

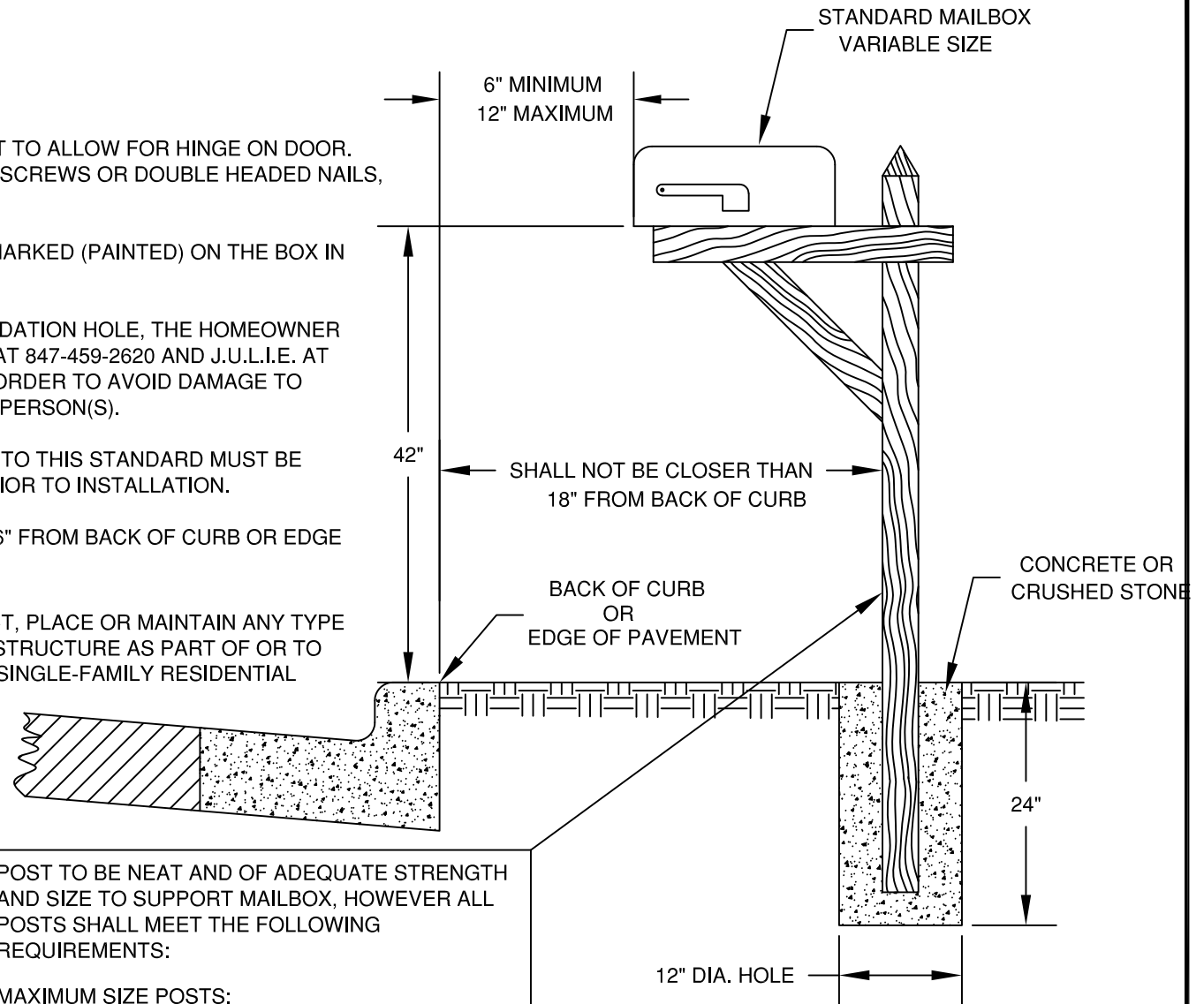

POST TO BE NEAT AND OF ADEQUATE STRENGTH AND SIZE TO SUPPORT MAILBOX, HOWEVER ALL POSTS SHALL MEET THE FOLLOWING REQUIREMENTS:

MAXIMUM SIZE POSTS:
 4" X 4" WOOD POST
 4-1/2" DIA. WOOD POST
 2" DIA. STEEL OR ALUMINUM POST

APPROVED BY UNITED STATES POSTAL SERVICE ON NOVEMBER 2, 1990.



VILLAGE OF WHEELING
 ENGINEERING DIVISION
 2 COMMUNITY BOULEVARD
 WHEELING, IL 60090
 WWW.WHEELINGIL.GOV

MAILBOX SUPPORT AND ATTACHMENT DESIGN

VILLAGE OF WHEELING SPECIFICATIONS AND DETAILS	REVISIONS		DETAIL NO.
	FILE LOCATION	MTP	
T:\ENGINEERING\STANDARDS	KAG	12-2-16 AUTOCAD FILE	
	KAG	10-22-20 NOTE 6	